

TREE SCHEDULE:- PLOT DETAILS:-

- T1- Silver Birch
- T2- Laburnum
- T3- Flowering Almond
- T4- Copper Acer
- T5- Acer
- T6- Holly
- T7- Magnolia
- T8- Wild Lilac
- T9- Yew
- T10- Apple
- T11- Ash
- T12- Hawthorne
- T13- Hazel Coppice
- T14- Bird Cherry
- T15- Field Maple

- PLOT 1  
Plot Area-610m<sup>2</sup>  
Floor Area-165m<sup>2</sup>  
No Beds- 3
- PLOT 2  
Plot Area-590m<sup>2</sup>  
Floor Area-165m<sup>2</sup>  
No Beds- 3



PROPOSED SITE PLAN 1:200

TREE PROTECTION:-

Tree protection fencing to be at least 1000mm outside the tree/tree's in question branch spread, or in accordance with Arboricultural requirements.

All protective fencing must be erected prior to any work commencing on-site. The fence will be erected in accordance with Planning Officer's/Local Authorities requirements/recommendation. The fence shall only be removed once all works are complete.

No chemicals or fuel shall be permitted to seep into the protected area. No works including storage, leveling, excavation shall be permitted within the protected area.

Identified trees that are not adequately protected, in the vent of damage all relevant parties may receive enforcement action and/or prosecution.

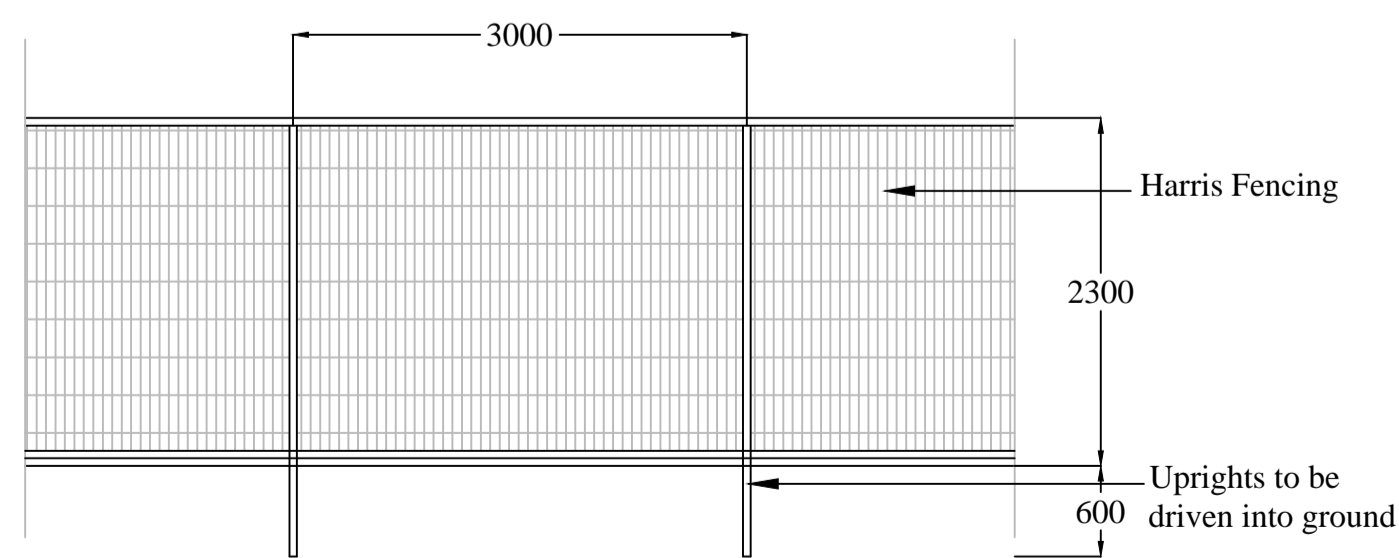

TREE PROTECTION FENCE ELEVATION 1:50

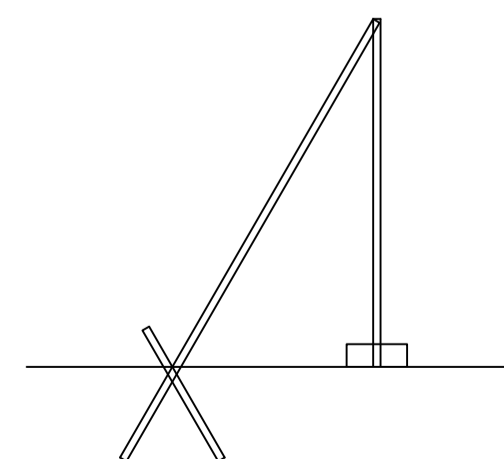

SECTION 1:50



ELEVATION/SECTION B 1:200



ELEVATION/SECTION B 1:200

Rev	Date	Revision

Rev	Date	Revision

Rev	Date	Revision

**dieter nelson**  
planning consultancy

Cleethorpes Business Centre,  
Wilson Road Industrial Estate,  
Humberston, Grimsby, NE Lincs.  
DN36 4AS  
Tel: 07875 750031  
Email: mail@dieterelson.com

Project	Proposed Residential Development to Rear of- 6 Holywell Road, Alford
Title	Proposed Site Plan & Tree Protection Details

Date	Sept 2013	Rev	-
Scale	Varies	Drwg No.	
Sheet	A1		.01